

Electric actuator VID10B

Advantages:

- Robust design with steel lifting unit
- High degree of protection and performance
- Efficiency optimized ball screw drive

Typical areas of application:

- Industrial and construction engineering
- Vehicle and boat construction
- Forestry and agricultural technology
- Antenna and solar technology

Key figures:

- DC motor with 12 V DC or 24 V DC
- Up to 7000 N (dynamic)
- Up to 67 mm/sec
- 13 600 N (static)
- Protection class IP54
- Ambient temperature -25 °C to +65 °C
- Duty cycle 25 %
- Overload clutch

Options:

- Potentiometer
- Adjustable limit switches
- Protection class IP65
- Manual emergency operation
- Mounting by clamps

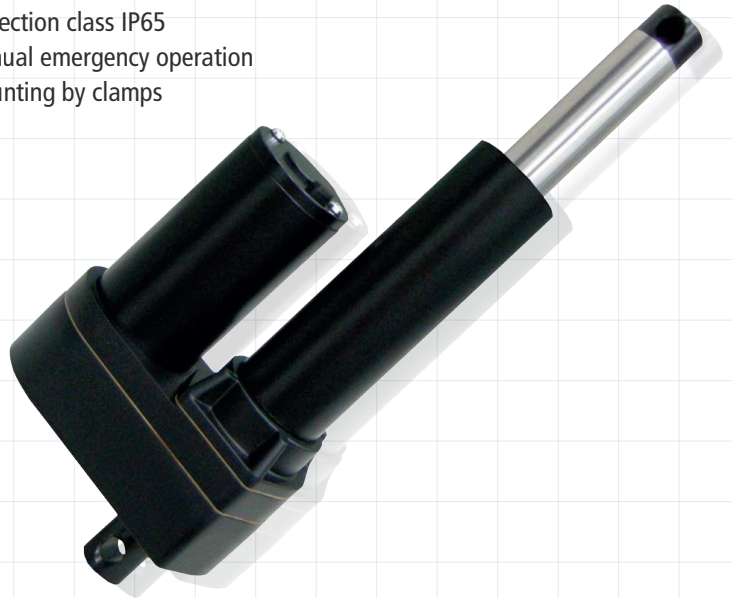

Drive data:

Ratio	Max. compression force dynamic [N]	Max. pulling force dynamic [N]	Speed,		Possible stroke lengths [mm]	12 V DC		24 V DC	
			no load	full load		Max. current no load	Max. current full load	Max. current no load	Max. current full load
			[mm/s]	[mm/s]		[A]	[A]	[A]	[A]
5:1	2500	2500	67	47	102-610	3.5	28	1.7	14
10:1	3500	3500	33.5	26.7	102-610	3.5	17	1.7	6.5
20:1	4500	4500	17	14.3	102-610	3.5	13.5	1.7	6.7
30:1	6000	6000	11	10	102-610	3.5	12.5	1.7	6.2
40:1	7000	7000	8.4	7.4	102-610	3.5	11.5	1.7	5.7

Load diagrams:

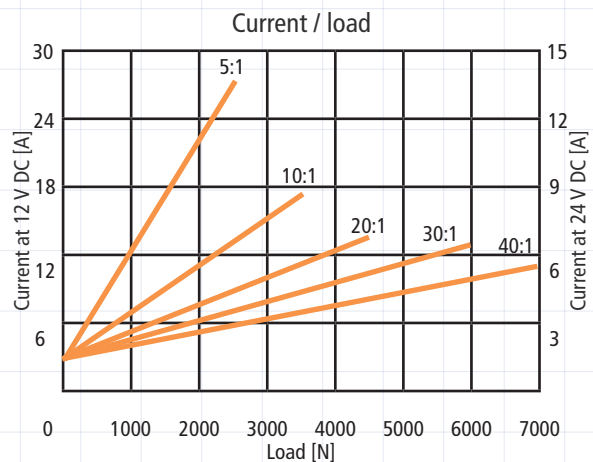
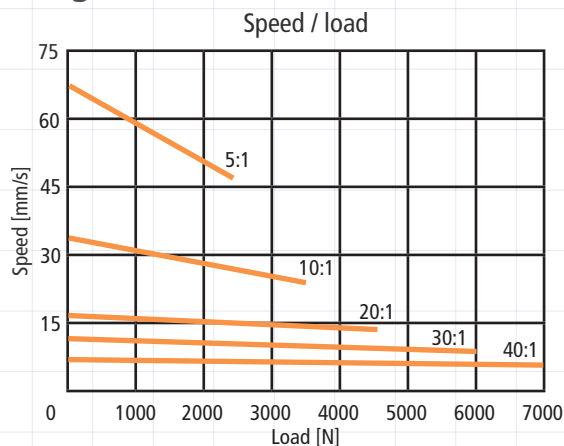

Type code:

VID10 - 24 - 20 - A - 100 - ES.MH...

Type	Voltage	Ratio	Ball screw	Stroke length	Options
	12 - 12 V DC	5 - 5:1		100 - 102 mm	ES - Limit switches, adjustable
	24 - 24 V DC	10 - 10:1		150 - 153 mm	POT - Potentiometer
		20 - 20:1		200 - 203 mm	MH - Manual emergency operation
		30 - 30:1		250 - 254 mm	I - Protection class IP65
		40 - 40:1		300 - 305 mm	C1, C2, C3, C4, C5 - Position of the housing bore
				450 - 457 mm	
				600 - 610 mm	

Dimensions (standard):

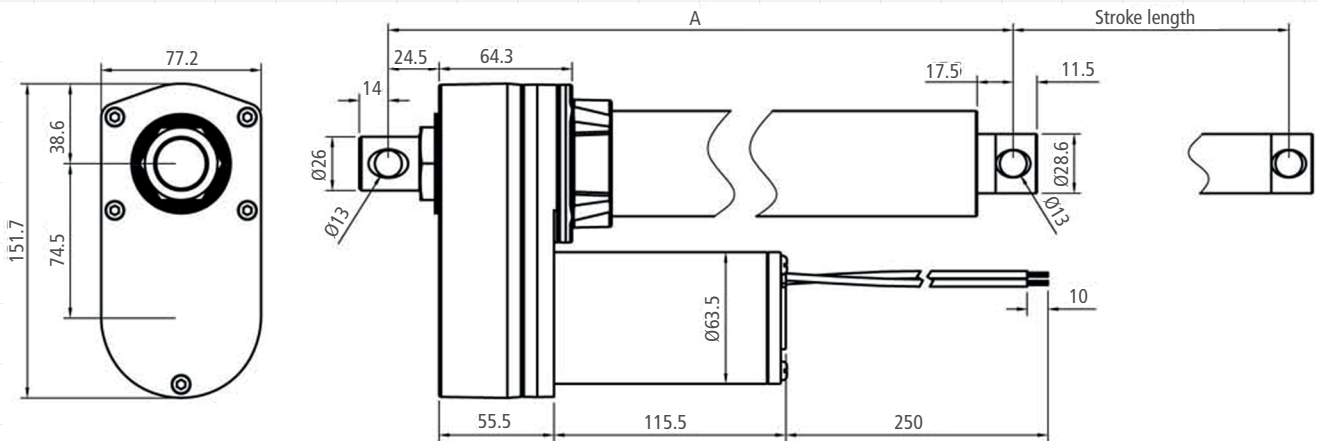

Stroke length (+/- 2.5 mm)	102 mm	153 mm	203 mm	254 mm	305 mm	457 mm	610 mm
Installation length A (+/- 3.8 mm)	302 mm	353 mm	404 mm	455 mm	506 mm	735 mm	888 mm

Dimensions (with limit switches and/or potentiometer):

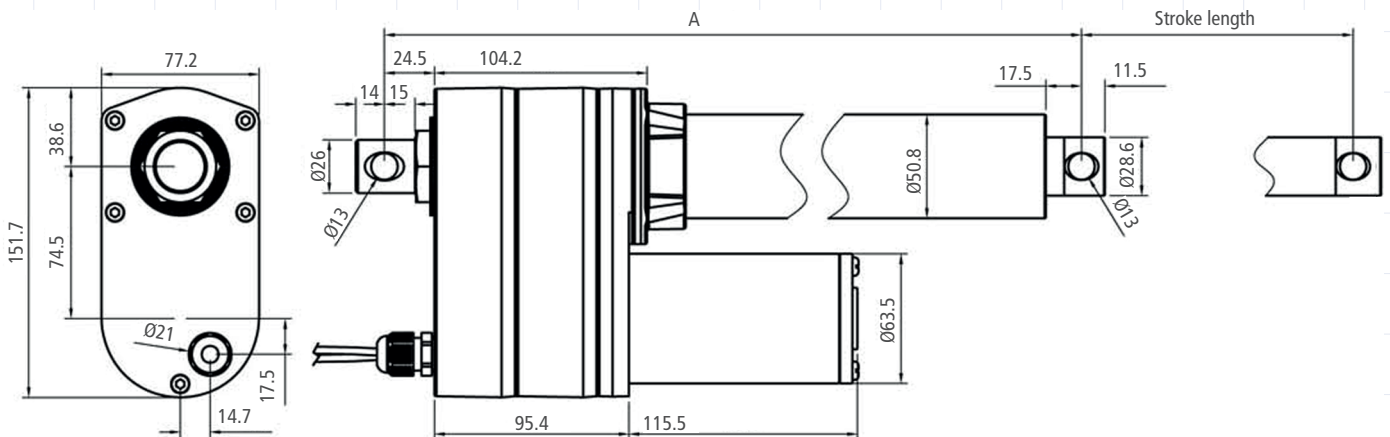

Stroke length (+/- 2.5mm)	102 mm	153 mm	203 mm	254 mm	305 mm	457 mm	610 mm
Installation length A (+/- 3.8mm)	342 mm	393 mm	444 mm	495 mm	546 mm	775 mm	928 mm

Setting the limit switches:

The extended end position is set via the upper cam disk, the retracted end position via the lower cam disk. If necessary, the end positions can be adjusted according to the following points.

To prevent damage to the plastic gear unit, the cam disks must be held in place while loosening or tightening the cam screw.

1. If the electric cylinder is attached, loosen the connections. Open the gearbox cover by loosening the 5 hexagon socket screws.
2. Make sure that the lifting tube does not rotate during motorized adjustment. Retract the electric cylinder electrically until the lower cam disk triggers the limit switch and the motor switches off. Turn the lifting rod manually to the desired retracted position.
3. Make sure that the lifting tube does not rotate during motorized adjustment. Extend the cylinder electrically until the desired position is reached. Adjust the upper cam disk until it triggers the limit switch.

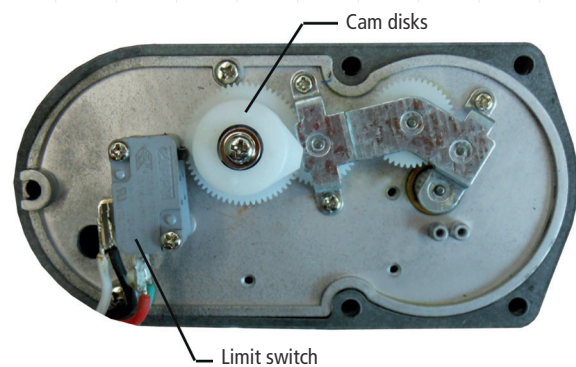
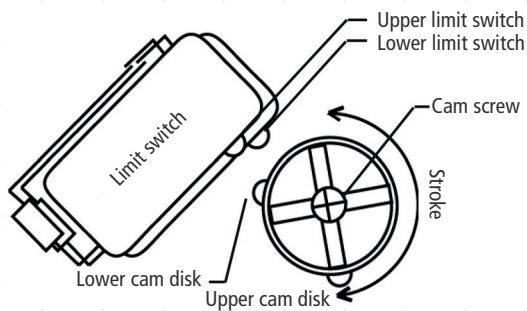

Potentiometer:

The resistance of the tapping of the potentiometer changes as a function of the stroke length and the actuating position of the electric cylinder according to the table below:

Resistance between blue and white conductor	
Stroke [mm]	Resistance (kΩ)
100	0.3 - 8.0
150	0.3 - 8.5
200	0.3 - 9.1
300	0.3 - 8.6
450	0.3 - 9.2
600	0.3 - 9.8
Tolerance: ± 0.3 (kΩ)	

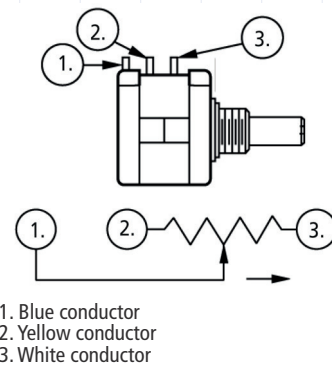

Attachment:

The lower fixing eye is fixed at an angle of 90° as standard.

It is possible to choose other angles (see left graphic) when ordering. Then add the corresponding designation C1 to C5 to the type code.

Furthermore, it is possible to order mounting clamps for pipe installation.

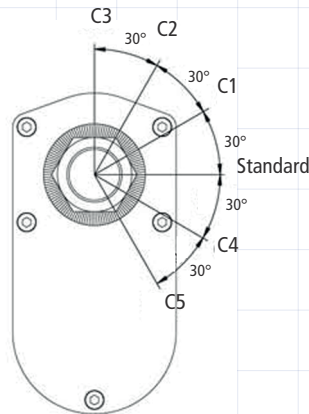

Attachment with mounting clamp:

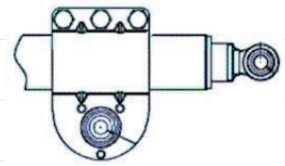

Installation note:

The piston rod extends or retracts according to the pin assignment. If limit switches are integrated in the cylinder, the motor stops automatically in the respective end position.

If no limit switches are integrated, it must be ensured that the motor is switched off before reaching the respective mechanical end position. The motor must be protected against overcurrent by a fuse.

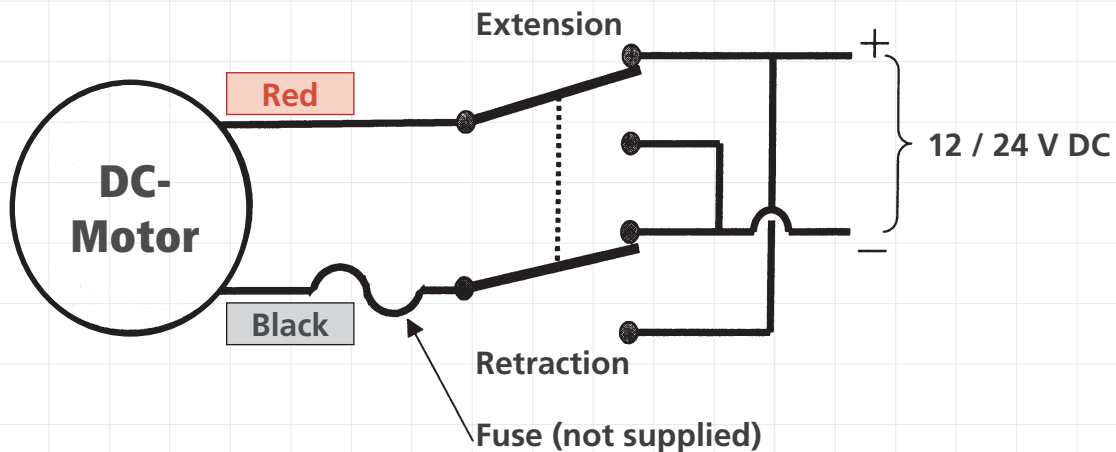

The load should always be centered in the direction of movement. Lateral forces should be avoided. They always shorten the service life and in extreme cases can interfere with the function or even destroy the device.

Ensure that the permissible load is not exceeded.

